LUBRICATION AND MAINTENANCE

CONTENTS

GENERAL INFORMATION	2	Front Wheel Bearings	19
MAINTENANCE SERVICE	8	Fuel Filter	11
Air Cleaner Element	13	Fuel Hoses, Vapor Hoses and Fuel Filler Cap	12
Automatic Transmission	16	Fuel System	12
Ball Joint, Steering Linkage Seals and Drive Shaft Boots	19	Ignition Cables	15
Brake Fluid	19	Manual Transmission	16
Brake Hoses	19	Oxygen Sensor	15
Canister	14	Rear Axle	20
Cooling System	17	Spark Plugs	14
Crankcase Emission Control System (PCV valve)	13	Turbocharger Air Intake Hoses and Oil Hoses	12
Disc Brake Pads	18	Vacuum Hoses, Secondary Air Hoses, Crankcase Ventilation Hoses and Water Hoses	12
Drive Belt	15	Valve Clearance	9
Engine Oil	8	RECOMMENDED LUBRICANTS AND LUBRICANT CAPACITIES TABLE	6
Engine Oil Filter	8	SCHEDULED MAINTENANCE TABLE	3
Evaporative Emission Control System – Except Canisters	14		
Exhaust System	20		

GENERAL INFORMATION

N00PA--

Maintenance and lubrication service recommendations have been compiled to provide maximum protection for the vehicle owner's investment against all reasonable types of driving conditions. Since these conditions vary with the individual vehicle owner's driving habits, the area in which the vehicle is operated and the type of driving to which the vehicle is subjected, it is necessary to prescribe lubrication and maintenance service on a time frequency as well as mileage interval basis.

Oils, lubricants and greases are classified and graded according to standards recommended by the Society of Automotive Engineers (SAE), the American Petroleum Institute (API) and the National Lubricating Grease Institute (NLGI).

MAINTENANCE SCHEDULES

Information for service maintenance is provided under "SCHEDULED MAINTENANCE TABLE".

Three schedules are provided; one for "Required Maintenance", one for "General Maintenance" and one for "Severe Usage Service".

SEVERE SERVICE

Vehicles operating under severe service conditions will require more frequent service.

Component service information is included in appropriate units for vehicles operating under one or more of the following conditions:

1. Trailer towing or police, taxi, or commercial type operation
2. Operation of Vehicle
 - (1) Short-trip operation at freezing temperature (engine not thoroughly warmed up)
 - (2) More than 50% operation in heavy city traffic during hot weather above 32°C (90°F)
 - (3) Extensive idling
 - (4) Driving in sandy areas
 - (5) Driving in salty areas
 - (6) Driving in dusty conditions

ENGINE OIL

The SAE grade number indicates the viscosity of engine oils, for example, SAE 30, which is a single grade oil. Engine oils are also identified by a dual number, for example, SAE 10W-30, which indicates a multigrade oil.

The API classification system defines oil performance in terms of engine usage. Only engine oil designed "For Service SF" or "For Service SF/CC", when available, should be used. These oils contain sufficient chemical additives to provide maximum engine protection. Both the SAE grade and the API designation can be found on the container.

GEAR LUBRICANTS

The SAE grade number also indicates the viscosity of Multipurpose Gear Lubricants.

The API classification system defines gear lubricants in terms of usage. Typically gear lubricants conforming to API GL-4 or GL-5 with a viscosity of SAE 80W or SAE 90 are recommended for manual transmission and rear axle MOPAR Hypoid Lubricant Part No. 4318058 plus MOPAR Hypoid Gear Oil Additive-Friction Modifier Part No. 4318060 or equivalent.

LUBRICANTS – GREASES

Semi-solid lubricants, bear the NLGI designation and are further classified as grades 0, 1, 2, 3 etc. Whenever "Chassis Lubricant" is specified, Multi-purpose Grease, NLGI grade 2, should be used. MOPAR Multi-Mileage Lubricant, Part Number 2525035 or equivalent, meets these requirement and is recommended.

FUEL USAGE STATEMENT

The use of premium unleaded gasoline having a minimum octane rating of 91, (R + M)/2 is recommended for use in this car in order to provide optimum vehicle performance. The use of premium unleaded gasoline having an octane rating higher than 87 may help to obtain improved vehicle performance.

Unleaded gasolines only must be used in vehicles equipped with catalyst emission control systems. All vehicles, so equipped, have labels located on the instrument panel and on the back of fuel filler lid that state, "UNLEADED GASOLINE ONLY". These vehicles also have fuel filler tubes especially designed to accept the smaller diameter unleaded gasoline dispensing nozzles only.

MATERIALS ADDED TO FUEL

Indiscriminate use of fuel system cleaning agents should be avoided. Many of these materials intended for gum and varnish removal may contain highly active solvents or similar ingredients that can be harmful to gasket and diaphragm materials used in fuel system component parts.

SCHEDULED MAINTENANCE TABLE

N000A-

SCHEDULED MAINTENANCE SERVICE FOR EMISSION CONTROL AND PROPER VEHICLE PERFORMANCE

Inspection and service should be performed any time a malfunction is observed or suspected. Retain receipts for all vehicle emission services to protect your emission warranty.

Emission Control System Maintenance	Service Intervals	Kilometers in Thousands	24	48	72	80	96
		Mileage in Thousands	15	30	45	50	60
Change Engine Oil Every 6 Months	or	Every 4,800 Km (3,000 Miles)					
Change Engine Oil Filter Every 12 Months	or	Every 9,600 Km (6,000 Miles)					
Check Jet Valve Clearances; Adjust as Required	at	X	X	X			X
Replace Fuel Filter Every 5 Years	or					X	
Check Fuel System (Tank, Pipe, Lines and Connections) for Leaks Every 5 Years	or					X	
Replace Air Cleaner Element	at		X				X
Replace Spark Plugs	at		X				X
Replace Ignition Cables Every 5 Years	or						X
Replace Vacuum Hoses, Secondary Air Hoses, Crankcase Ventilation Hoses and Water Hoses Every 5 Years	or						X
Replace Fuel Hoses, Vapor Hoses and Fuel Filler Cap Every 5 Years	or					X	
Check Crankcase Emission Control System (PCV Valve); Clean Every 5 Years	or						X
Check Evaporative Emission Control System (Except Canister) for Leaks and Clogging Every 5 Years	or						X
Replace Canister	at					X	
Replace Oxygen Sensor	at					X	
Replace Turbocharger Air Intake Hoses and Oil Hose Every 5 Years	or						X

GENERAL MAINTENANCE SERVICE FOR PROPER VEHICLE PERFORMANCE

General Maintenance	Service Intervals	Kilometers in Thousands	24	48	72	80	96
		Mileage in Thousands	15	30	45	50	60
Cooling System	Check and Service as Required Every 12 Months	or	X	X	X		X
Engine Coolant	Change Engine Coolant Every 2 Years	or		X			X
Brake Fluid	Change Fluid Every 4 Years	or					X
Disc Brake Pads (Front and Rear)	Inspect for Wear Every 12 Months	or	X	X	X		X
Brake Hoses	Check for Deterioration or Leaks Every 12 Months	or	X	X	X		X
Ball Joint and Steering Linkage Seals, Steering and Drive Shaft Boots	Inspect for Grease Leaks and Damage Every 2 Years	or		X			X
Wheel Bearings	Lubricate Grease Every 2 Years	or		X			X
Exhaust System (Pipe Connections, Converter Heat Shield Damage or Corrosion)	Check and Service as Required Every 12 Months	or	X	X	X		X
Manual Transmission	Inspect Oil Level	at		X			X
Rear Axle	Change Oil	at		X			X
Drive Belt (for Water Pump and Alternator)	Replace Belt	at		X			X

SCHEDULED MAINTENANCE UNDER SEVERE USAGE CONDITIONS

The maintenance items should be performed according to the following table:

Maintenance Item	Service to be Performed	Mileage Intervals Kilometers in Thousands (Miles in Thousands)				Severe Usage Conditions							
		24 (15)	48 (30)	72 (45)	96 (60)	A	B	C	D	E	F	G	H
Engine Oil	Change Every 3 Months or	Every 4,800 Km (3,000 Miles)				X	X	X	X			X	
Engine Oil Filter	Replace Every 6 Months or	Every 9,600 Km (6,000 Miles)				X	X	X	X			X	
Air Cleaner Element	Replace	More Frequently				X				X			
Crankcase Emission-Control System	Check and Clean as Required	More Frequently				X							
Spark Plugs	Replace at	X	X	X	X		X		X				
Disc Brake Pads (Front and Rear)	Inspect for Wear	More Frequently				X					X		
Automatic Transmission	Change Fluid at		X		X		X				X	X	

Severe usage conditions

- | | |
|--|---|
| A- Driving in dusty conditions | E- Driving in sandy areas |
| B- Trailer towing or police, taxi, or commercial type operation | F- Driving in salty areas |
| C- Extensive idling | G- More than 50% operation in heavy city traffic during hot weather above 32°C (90°F) |
| D- Short-trip operation at freezing temperatures (engine not thoroughly warmed up) | H- Driving off-road |

RECOMMENDED LUBRICANTS AND LUBRICANT CAPACITIES TABLE

N00RA

RECOMMENDED LUBRICANTS

Parts	Specifications	Remarks
Engine oil	API classification SF or SF/CC	For further details, refer to SAE viscosity number
Manual transmission	API classification GL-4 or higher	MOPAR Hypoid Gear Oil or equivalent
Automatic transmission	Automatic transmission fluid "DEXRON II" or "DEXRON" type	MOPAR Automatic Transmission Fluid or equivalent
Rear axle		MOPAR Hypoid Gear Lubricant Part No. 4318058 plus MOPAR Hypoid Gear Oil Additive-Friction Modifier Part No. 4318060 or equivalent
Power steering	Automatic transmission fluid "DEXRON II" or "DEXRON" type	MOPAR Automatic Transmission Fluid or equivalent
Brake and clutch	Conforming to DOT 3	MOPAR Brake Fluid or equivalent
Front wheel bearing	Multipurpose grease NLGI Grade 2	MOPAR Front Wheel Bearing Grease, MOPAR Multi-Mileage Lubricant or equivalent
Cooling system	High quality ethylene glycol	MOPAR Antifreeze Permanent Type Coolant or equivalent
Transmission linkage, parking brake cable mechanism, hood lock and hook, door latch, hatch latch, seat adjuster	Multipurpose grease NLGI Grade 2	MOPAR Lubricant or equivalent
Door hinges, hatch hinges	Engine oil	

LUBRICANT CAPACITIES TABLE

Description	Metric measure	U.S. measure
Engine Oil		
Crankcase (excludes oil filter)	3.8 liters	4 qts.
Oil filter	0.5 liter	1/2 qt.
Oil cooler	0.4 liter	1/2 qt.
Cooling System (including heater and engine coolant reserve system)	9.0 liters	9.5 qts.
Manual Transmission	2.3 liters	2.4 qts.
Automatic Transmission	7.0 liters	7.4 qts.
Rear Axle	1.3 liters	2.7 pints
Power Steering	1.1 liters	1.2 qts.
Fuel Tank	75 liters	19.8 gals.

SELECTION OF LUBRICANTS

ENGINE OIL

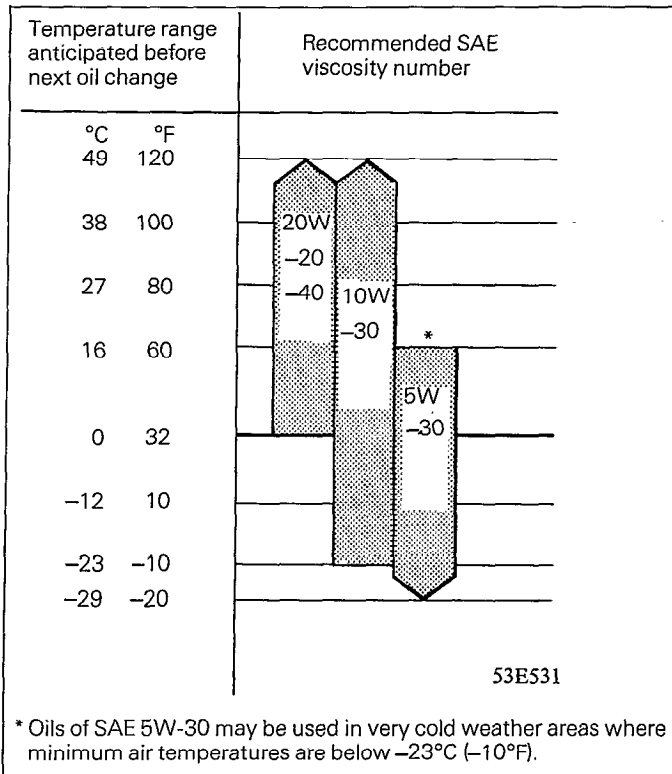

MANUAL TRANSMISSION

Lubricants	API classification GL-4 or higher
Viscosity range	SAE 80W SAE 75W-85W

REAR AXLE (limited slip differential)

Refer to P.3-10.

SELECTION OF ENGINE COOLANT

ENGINE COOLANT

Relation between Engine Coolant Concentration and Specific Gravity

Engine coolant temperature °C (°F) and specific gravity					Freezing temperature °C (°F)	Safe operating temperature °C (°F)	Engine coolant concentration (Specific volume)
10 (50)	20 (68)	30 (86)	40 (104)	50 (122)			
1.054	1.050	1.046	1.042	1.036	-16 (3.2)	-11 (12.2)	30 %
1.063	1.058	1.054	1.049	1.044	-20 (-4)	-15 (5)	35 %
1.071	1.067	1.062	1.057	1.052	-25 (-13)	-20 (-4)	40 %
1.079	1.074	1.069	1.064	1.058	-30 (-22)	-25 (-13)	45 %
1.087	1.082	1.076	1.070	1.064	-36 (-32.8)	-31 (-23.8)	50 %
1.095	1.090	1.084	1.077	1.070	-42 (-44)	-37 (-35)	55 %
1.103	1.098	1.092	1.084	1.076	-50 (-58)	-45 (-49)	60 %

Example

The safe operating temperature is -15°C (5°F) when the measured specific gravity is 1.058 at the engine coolant temperature of 20°C (68°F).

Caution

1. If the concentration of the engine coolant is below 30%, the anti-corrosion property will be adversely affected. In addition, if the concentration is above 60%, both the anti-freeze and engine cooling properties will decrease, affecting the engine adversely. For these reasons, be sure to maintain the concentration level within the specified range.
2. Do not use a mixture of different brands of anti-freeze.

MAINTENANCE SERVICE

N00SAAA

ENGINE OIL (Change)

Always use lubricants which conform to the requirements of the API classification "For Service SF" or "For Service SF/CC" when available, and have the proper SAE grade number for the expected temperature range.

Never use nondetergent or straight mineral oil.

- (1) After warming up the engine, remove the oil filler cap.
- (2) Remove the drain plug to allow the engine oil to drain.
- (3) Replace the drain plug gasket with a new one and tighten the drain plug.
- (4) Pour new engine oil through the oil filler.

Engine oil quantity (excludes oil filter):

3.8 lit. (4 qts.)

Oil filter 0.5 lit. (½ qt.)

Oil cooler 0.4 lit. (½ qt.)

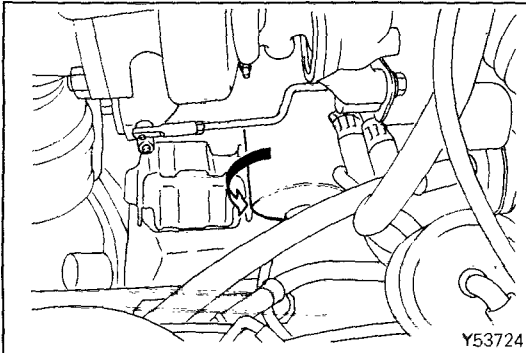

ENGINE OIL FILTER (Change)

N00SABA

The quality of replacement filters varies considerably. Only high quality filters should be used to assure most efficient service. Genuine oil filters require that the filter is capable of withstanding a pressure of 256 psi and high quality filters are recommended as follows:

Oil Filter Part Number:

Mitsubishi Genuine Parts MD031805

NOTE

Factory installed Mitsubishi Engine Oil Filter Part No. MD084693 or MD031805.

ENGINE OIL FILTER SELECTION

This vehicle is equipped with a full-flow, throw-away oil filter. The same type of replacement filter is recommended as a replacement filter for this vehicle. It is possible, particularly in cold weather, that this vehicle may develop high oil pressure for a short duration. You should be sure that any replacement filter used on this vehicle is a high-quality filter and is capable of withstanding a pressure of 256 psi (manufacturer's specifications) to avoid filter and engine damage. The following is a high-quality filter and is strongly recommended for use on this vehicle: Mitsubishi Engine Oil Filter P/N MD084693 or MD031805.

Any replacement oil filter should be installed in accordance with the oil filter manufacturer's specifications and installation instructions.

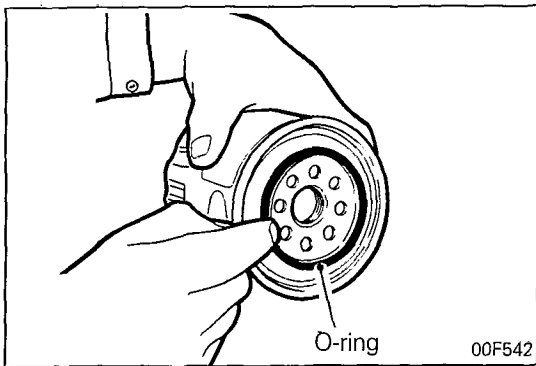

- (1) Use filter wrench or the like to remove oil filter.
- (2) Apply a thin film of engine oil to the surface of gasket before screwing filter on.
- (3) Then tighten filter enough by hand.
- (4) Start and run engine and check for engine oil leaks.
- (5) After stopping engine, check oil level and refill as necessary.

VALVE CLEARANCE (Check and adjust as required)

N00SACH

Incorrect valve clearances will not only result in unsteady engine operation, but will also cause excessive noise and reduced engine output.

Check the valve clearances and adjust as required while the engine is hot.

Valve-to-rocker arm clearances:

Jet valves 0.25 mm (.010 in.)

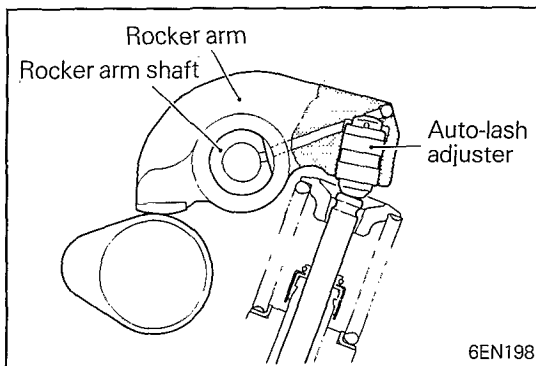

VALVE CLEARANCE ADJUSTMENT

INTAKE AND EXHAUST VALVES

The auto-lash adjuster is installed to the rocker arm so that the valve clearance adjustment is maintenance-free.

For additional information regarding the auto-lash adjuster, refer to GROUP 9 ENGINE.

JET VALVE

Caution

The cylinder head bolts should be retightened before attempting this adjustment.

- (1) Warm up the engine until the engine coolant is heated to 85 to 95°C (185 to 205°F).
- (2) Remove all spark plugs from the cylinder head for easy operation.
- (3) Remove the air intake pipe.
- (4) Remove the rocker cover.

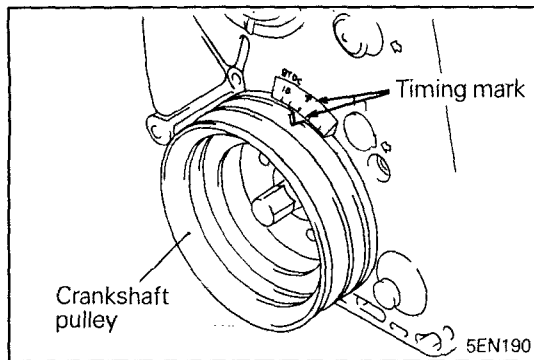

- (5) Set the No. 1 piston at top dead center on the compression stroke.

Turn the crankshaft clockwise until the notch on pulley is lined up with the "T" mark on timing chain cover. In this state, check that the mating mark on the camshaft sprocket is at the position shown in the illustration.

Caution

Do not turn the crankshaft counterclockwise.

NOTE

If the mating mark is at the opposite side, No. 4 piston is at top dead center on the compression stroke.

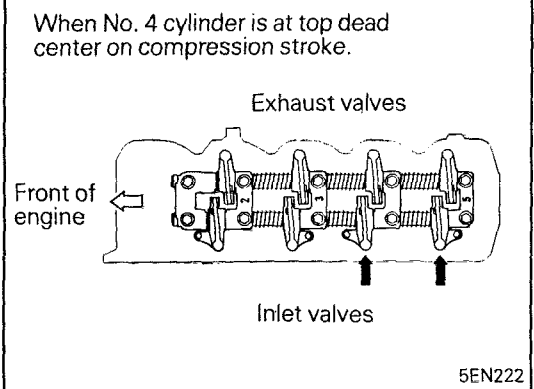
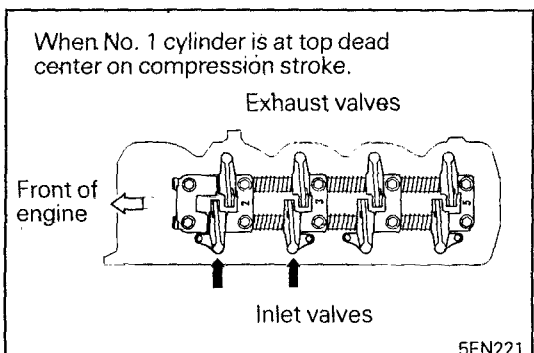
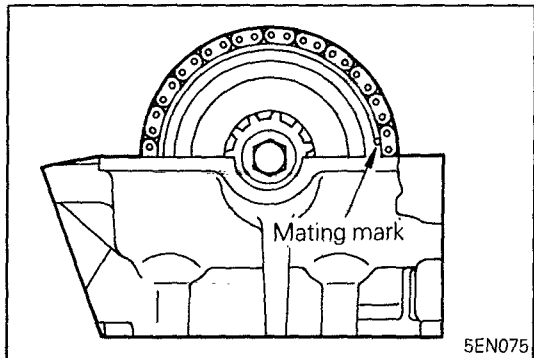

- (6) Measure the valve clearance at points indicated by arrows.

Standard value (on hot engine): 0.25 mm (.010 in.)

NOTE

The valve clearance on cold engine is 0.17 mm (.007 in.).

- (7) If the jet valve clearance is not as specified, loosen the lock nut and adjust the clearance using a feeler gauge while turning the adjusting screw.

Caution

The jet valve spring has a small tension and the adjustment is somewhat delicate. Be careful not to push in the jet valve by turning adjusting screw too much.

- (8) While holding the adjusting screw with a screwdriver to prevent it from turning, tighten the lock nut to specified torque.

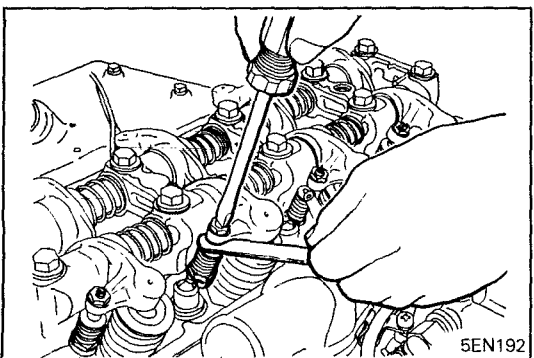

- (9) Turn the crankshaft through 360° to line up the notch on the crankshaft pulley with the "T" mark on timing chain cover.
 (10) Check the other valves and if they are out of specification, readjust according to steps (7) and (8).

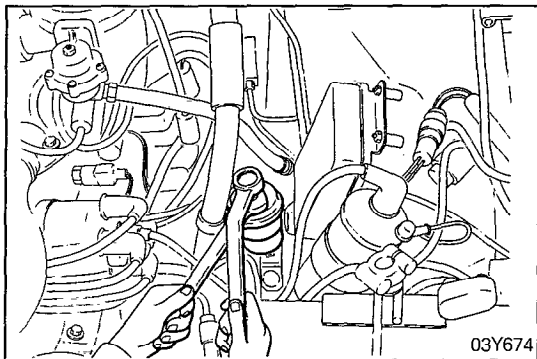
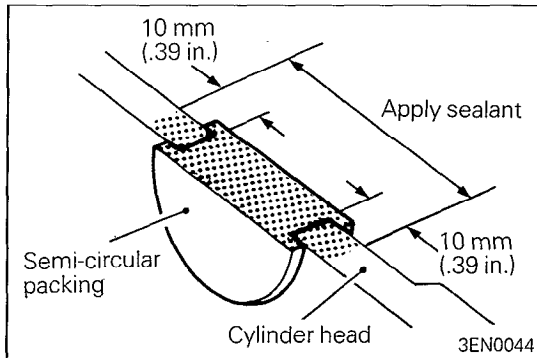
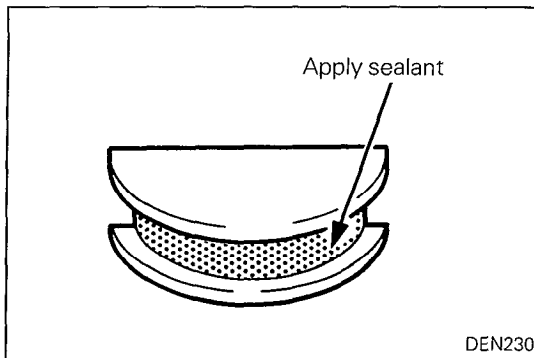

(11) Apply specified sealant to the semi-circular packing on the portions shown in the illustration.

Recommended adhesive: MOPAR Part No. 4318025 or equivalent

(12) Install the rocker cover.

(13) Install the air intake pipe.

(14) Install the spark plugs.

FUEL FILTER (Replace)

N00SAFA

The fuel filter should be replaced regularly because its performance is reduced by dirt and water collected over an extended period of use. Replace as required.

FUEL SYSTEM (Check for leaks)

N00SAGA

TANK, LINES AND CONNECTIONS

- (1) Check for damage or leakage in the fuel lines and connections.
- (2) Inspect the surface of fuel hoses for heat and mechanical damage. Hard and brittle rubber, cracking, checking, tears, cuts, abrasions and excessive swelling indicate deterioration of the rubber.
- (3) If the fabric casing of the rubber hose is exposed by cracks and abrasions in the fuel system, the hoses should be changed.

VACUUM HOSES, SECONDARY AIR HOSES, CRANKCASE VENTILATION HOSES AND WATER HOSES (Replace)

N00SAHA

Replace them and make sure that hoses do not come in contact with any heat source on moving component which might cause heat damage or mechanical wear.

FUEL HOSES, VAPOR HOSES, AND FUEL FILLER CAP (Replace)

N00SAIA

Service procedures to check the hoses for damage are the same as those described in the section "Vacuum hoses, secondary air hoses, crankcase ventilation hoses and water hoses".

For removal and installation procedures, refer to GROUP 14 FUEL SYSTEM – Fuel Tank, Fuel Line and Vapor Line.

TURBOCHARGER AIR INTAKE HOSES AND OIL HOSES (Replace) – for fuel-injection turbocharged vehicles

N00SAJA

The turbocharger air intake hoses and oil hoses must be replaced periodically with new ones. The air entered from outside the air cleaner filter may make intake air dirty, resulting in engine power less than normal.

The oil leakage from oil hose may provide improper lubrication in the turbocharger, resulting in engine power less than normal. For removal and installation procedure, refer to GROUP 11 INTAKE AND EXHAUST SYSTEM – Turbocharger.

AIR CLEANER ELEMENT (Replace)

N00SAKD

The air cleaner element will become dirty and loaded with dust during use, and the filtering effect will be substantially reduced. Replace it with a new one.

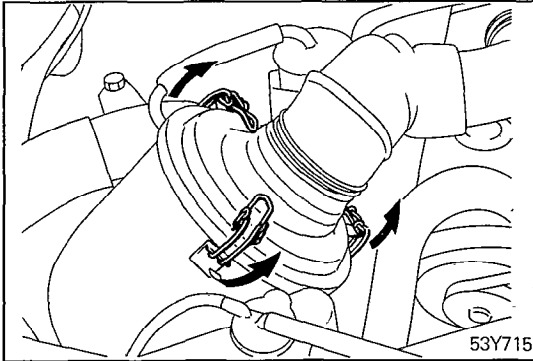

- (1) Unclamp and remove the cleaner cover.

Caution

Remove the air cleaner cover, paying attention to the air flow sensor attached to the cover.

- (2) Take out the air cleaner element.
- (3) Set a new air cleaner element and clamp the cleaner cover.

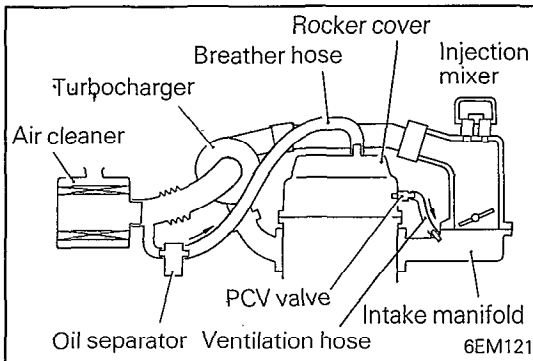
**CRANKCASE EMISSION CONTROL SYSTEM (PCV valve) (Clean)**

N00SALA

The crankcase ventilation system must be kept clean to maintain good engine performance.

Periodic servicing is required to remove combustion products from the PCV valve.

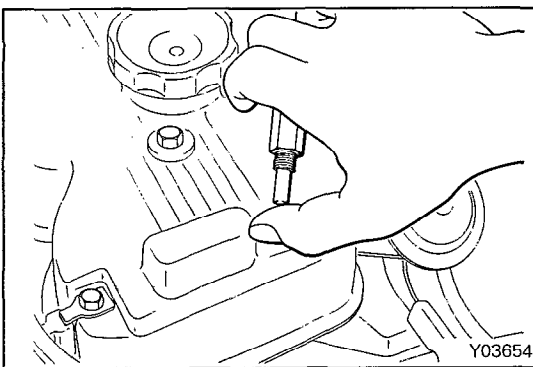

- (1) Disconnect the ventilation hose from the positive crankcase ventilation (PCV) valve. Then, remove PCV valve from the rocker cover and reconnect it to the ventilation hose.
- (2) Idle the engine and put a finger to the open end of PCV valve to make sure that intake manifold vacuum is felt on the finger.

NOTE

At this time, the plunger inside the PCV valve moves back and forth.

- (3) If vacuum is not felt on finger, clean the PCV valve and ventilation hose in cleaning solvent or replace if necessary.

EVAPORATIVE EMISSION CONTROL SYSTEM (Check for leaks and clogging) – except canisters

N00SAMA

- (1) If the fuel-vapor vent line is clogged or damaged, a fuel-vapor mixture escapes into the atmosphere causing excessive emissions. Disconnect the line at both ends, and blow it clean with compressed air. Remove the filler cap from the filler pipe and check to see if there is evidence that the packing makes improper contact to the filler pipe.
- (2) The overfill limiter (two-way valve) installed on the vapor line between the canister inlet and fuel tank outlet should be checked for correct operation.

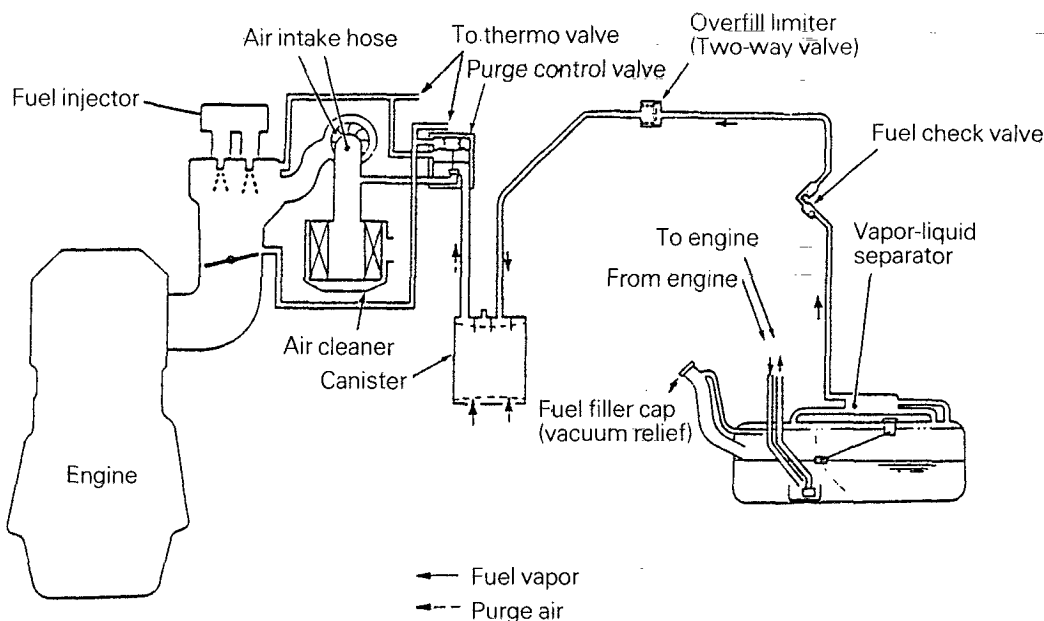

5EN026

CANISTER (Replace)

N00SANA

If or when the canister filter becomes clogged, the purge air volume will decrease and consequently, the canister capacity will be reduced.

For removal and installation procedures, refer to GROUP 14 FUEL SYSTEM – Fuel Line and Vapor Line.

SPARK PLUGS (Replace)

N00SA0A

- (1) Spark plugs must fire properly to assure proper engine performance and emission control. Therefore, they should be replaced periodically with new ones.
- (2) The new plugs should be checked for the proper gap.

Spark plug gap:

NGK, CHAMPION

1.0 – 1.1 mm (.039 – .043 in.)

NIPPONDENSO

W22EP-U10, W22EPR-U10

0.9 – 1.0 mm (.035 – .039 in.)

Other type

1.0 – 1.1 mm (.039 – .043 in.)

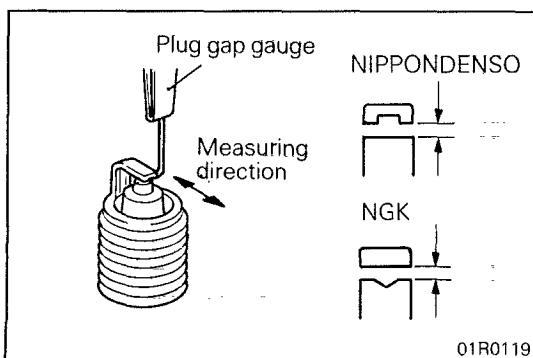

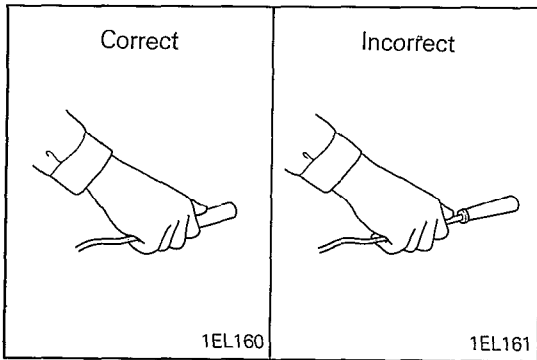

IGNITION CABLES (Replace)

N00SAPA

The ignition cables should be replaced periodically with new ones. After replacing, make sure that the ignition cables and terminals are properly connected and fully seated.

NOTE

When disconnecting an ignition cable, be sure to hold cable cap. If the cable is disconnected by pulling on the cable alone, an open circuit might result.

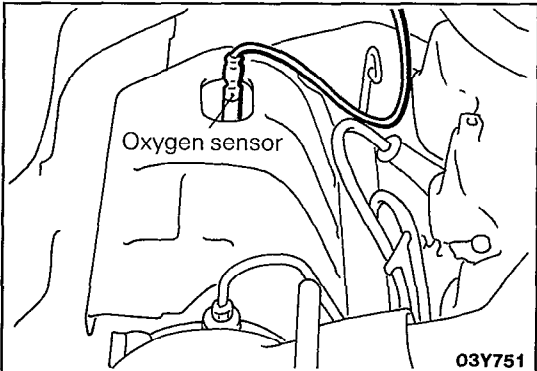

OXYGEN SENSOR (Replace)

N00SAQA

The oxygen sensor is a device which controls the fuel mixture. If the oxygen sensor is damaged, the exhaust-gas cleaning effect as well as driveability deteriorates. Therefore, it should be replaced periodically with a new one.

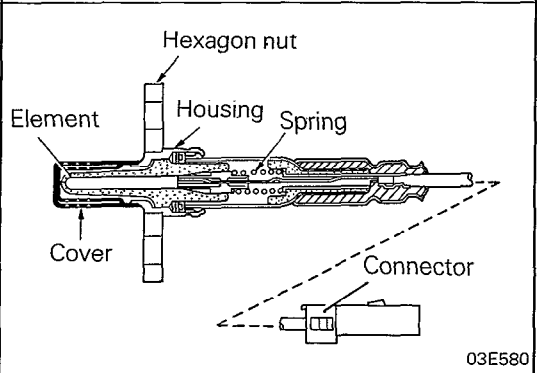

DRIVE BELT (Replace)

N00SBBA

Replace the drive belts with new ones, and make sure there is no interference between the belt and other engine components.

Then, check the tension of the belt for the water pump and alternator. The deflection of the belt must be specified listed below when depressed at a point midway between the water pump pulley and the alternator pulley with a force of 100 N (22 lbs.).

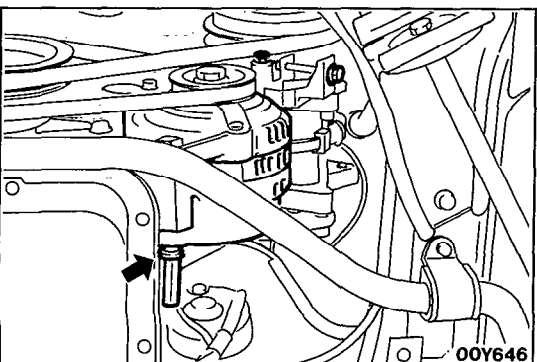

- (1) Remove the air conditioner compressor belt and/or power steering oil pump belt if equipped.
- (2) Loosen the alternator support bolt nut.

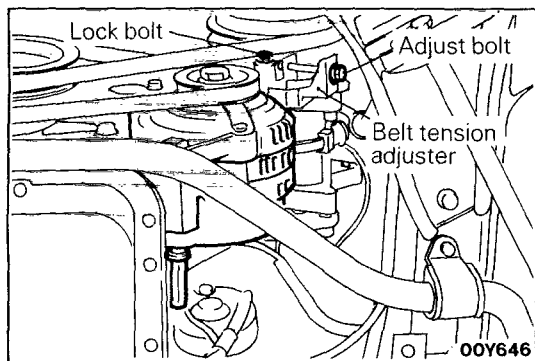

- (3) Loosen the belt tension adjuster lock bolt.
- (4) Turn the adjust bolt to reduce the belt tension.
- (5) Remove the belt.
- (6) Install a new belt and turn the adjust bolt to adjust the belt tension.

Standard value: 7 – 10 mm (.28 – .39 in.)

- (7) Tighten the lock bolt.
- (8) Tighten the alternator support bolt nut.

MANUAL TRANSMISSION (Inspect oil level)

N00SBCE

Inspect each component for evidence of leakage, and check the oil level by removing the filler plug. If the oil is contaminated, it is necessary to replace it with new oil.

- (1) With the vehicle parked at a level place, remove the filler plug and make sure that the oil is at the same level as the lower surface of the threaded hole.
- (2) Check to see that transmission fluid is free of excessive contamination and has proper viscosity.

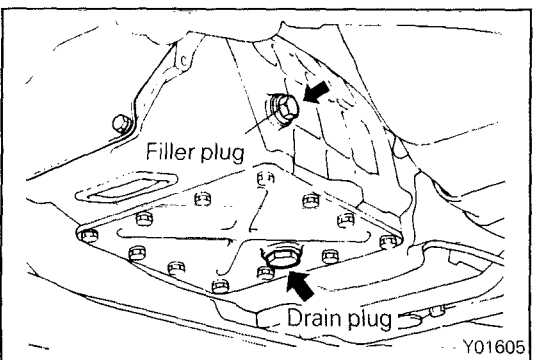
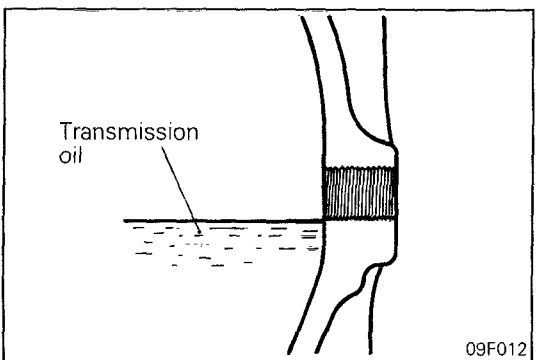
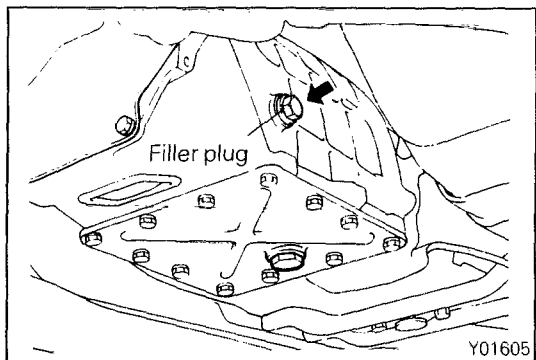

TRANSMISSION FLUID (Replace)

- (1) With the vehicle parked at a level place, remove the oil drain plug to drain transmission fluid.
- (2) Replace packing with a new one and install the oil drain plug.
- (3) Pour transmission fluid in the filler plug hole until the fluid is at the same level as the bottom of the plug hole.

Total transmission fluid capacity: 2.3 lit. (2.4 qts.)

AUTOMATIC TRANSMISSION (Change fluid)

N00SBDC

Drain the fluid and check whether there is any evidence of contamination.

Replenish with new fluid after the cause of any contamination has been corrected.

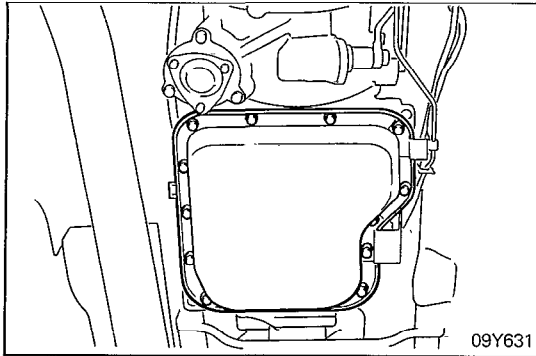

- (1) Loosen the oil pan screws and tap the oil pan at one corner to break it loose and allow automatic transmission fluid to drain.
- (2) Drain automatic transmission fluid remaining in bottom of oil pan after its removal.
- (3) Install oil pan with new gasket and tighten oil pan screws, 6 to 8 Nm (4.4 to 5.7 ft.lbs.).

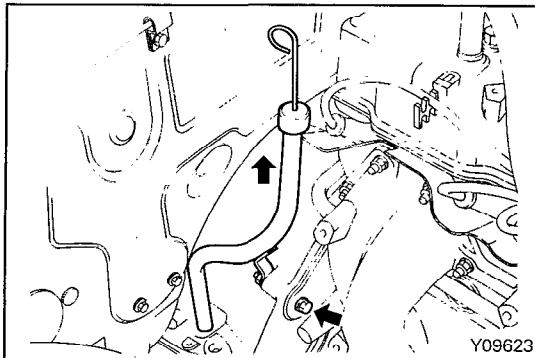

- (4) Pour 5 liters (5.3 qts.) of "DEXRON II" ATF into case through dipstick hole. [Total quantity of ATF required is approx. 7.2 liters (7.6 qts.). Actually however, approx. 5.5 liters (5.8 qts.) of fluid can be replaced because rest of fluid remains in torque converter.]
- (5) Start engine and allow to idle for at least two minutes. Then, with parking brake on, move selector lever momentarily to each position, ending in "N" Neutral position.

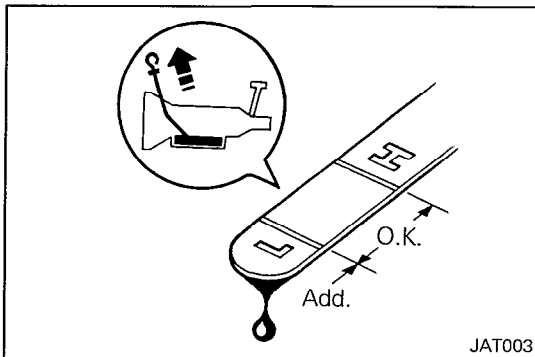

- (6) Add sufficient ATF to bring fluid level to lower mark. Recheck fluid level after transmission is at normal operating temperature. Fluid level should be between upper and lower marks. Insert dipstick fully to prevent dirt from entering transmission.

COOLING SYSTEM (Check and service as required)

N00SBEA

Check the cooling system parts, such as radiator, heater, and oil cooler hoses, thermostat and connections for leakage and damage.

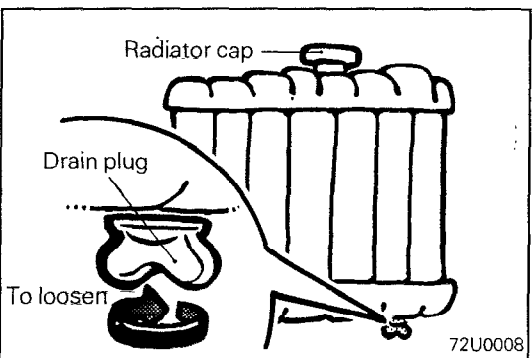
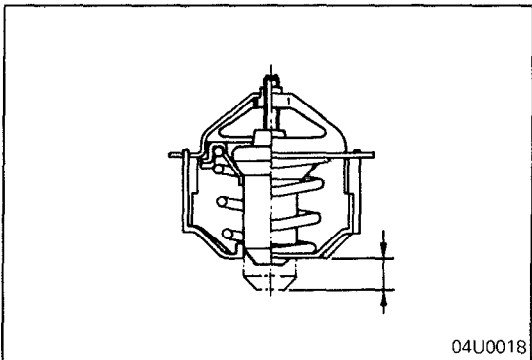
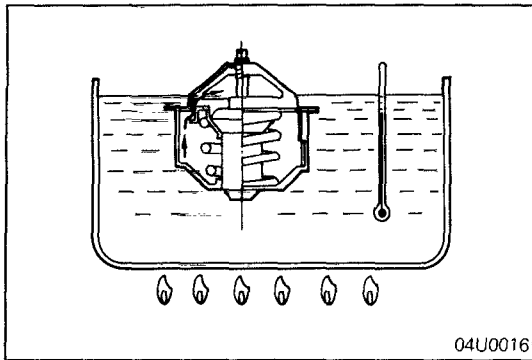
**THERMOSTAT (Inspect)**

- (1) Remove the thermostat.
- (2) Replace the thermostat if the valve is open even slightly.
- (3) Replace if greatly deformed, damaged or broken.
- (4) Remove rust and fur from the valve if found on the valve.
- (5) Fill a container with water and immerse the thermostat. While stirring water, increase water temperature and check to see that thermostat valve opening temperature and full-open temperature [valve lift at full open position is 8 mm (.3 in.) or more] are as specified below.

Standard value:

Valve opening temperature

88 ± 1.5°C (190 ± 3°F)

Full-open temperature 100°C (212°F)

NOTE

Valve lift is calculated by finding difference between the valve height measured at full-close state and the valve height measured at full-open temperature.

REPLACE ENGINE COOLANT

- (1) Set the temperature control lever to the hot position.
- (2) Remove the radiator cap.
- (3) Loosen the drain plug to drain the engine coolant.
- (4) Drain the engine coolant from the reserve tank.
- (5) After draining the engine coolant, tighten the drain plug securely.
- (6) Supply the engine coolant into the radiator until it is filled up to its filler neck.
- (7) Supply the engine coolant into the reserve tank.
- (8) After warming the engine until the thermostat opens, remove the radiator cap and check the engine coolant level.
- (9) Supply the engine coolant into the radiator until it is filled up to its filler neck, and install the radiator cap securely.
- (10) Fill the reserve tank with engine coolant up to the "FULL" line.

DISC BRAKE PADS (Inspect for wear)

N00SBFB

Check for fluid contamination and wear. Replace complete set of pads if defective.

Caution

The pads for the right and left wheels should be replaced at the same time. Never "split" or intermix brake pad sets. All four pads must be replaced as a complete set.

Thickness of lining (A):

Limit 2.0 mm (.08 in.)

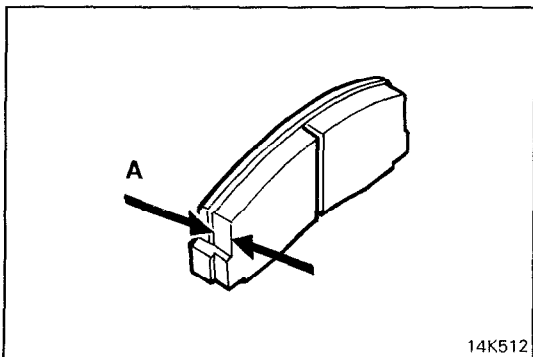

BRAKE HOSES (Check for deterioration or leaks)

N00SBHA

Inspection of brake hoses and tubing should be included in all brake service operations.

The hoses should be checked for:

- (1) Correct length, severe surface cracking, pulling, scuffing or worn spots. (If the fabric casing of the hoses is exposed by cracks or abrasion in the rubber hose cover, the hoses should be replaced. Eventual deterioration of the hose may occur, with possible bursting failure.)
- (2) Faulty installation, casing twisting or interference with wheel, tire or chassis.

BRAKE FLUID (Replace) – including the clutch fluid

N00SBIA

- (1) Check the brake and clutch system for leakage before replacing brake fluid. Completely drain the brake fluid with the bleeder screws loosened on each system and refill the brake and clutch system with new brake fluid.

Specified brake fluid: MOPAR Brake Fluid Part Number 2933249 or equivalent

- (2) The reservoir cap must be fully tightened to avoid contamination from foreign matter or moisture.

DO NOT ALLOW PETROLEUM BASE FLUID TO CONTAMINATE THE BRAKE FLUID – SEAL DAMAGE WILL RESULT.

Caution

Take care in handling brake fluid as it is harmful to the eyes and may also cause damage to painted surfaces.

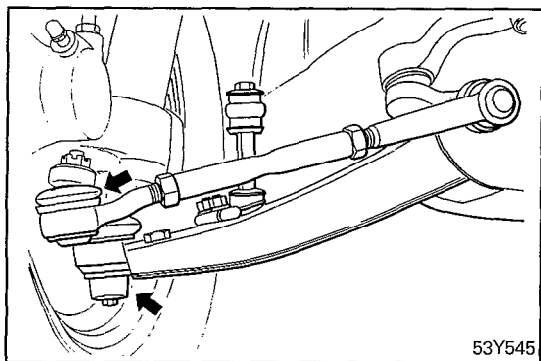
**BALL JOINT, STEERING LINKAGE SEALS AND DRIVE SHAFT BOOTS (Inspect for grease leaks and damage)**

N00SBJA

- (1) These components, which are permanently lubricated at the factory, do not require periodic lubrication. Damaged seals and boots should be replaced to prevent leakage or contamination of the grease.
- (2) Inspect the dust cover and boots for proper sealing, leakage and damage. Replace them if defective.

FRONT WHEEL BEARINGS (Inspect for grease leaks)

N00SBKE

Inspect for evidence of grease leakage around the hub cap and the back of the hub. If there is leakage of grease, remove the hub and inspect its oil seal for damage. Clean the grease off the hub and bearing, and repack with specified new grease.

Specified grease: MOPAR Multi-mileage Lubricant Part Number 2525035 or equivalent

EXHAUST SYSTEM (CONNECTION PORTION OF MUFFLER, PIPINGS AND CONVERTER HEAT SHIELDS) (Check and service as required)

N00SBLA

- (1) Check for holes and gas leaks due to damage, corrosion, etc.
- (2) Check the joints and connections for looseness and gas leaks.
- (3) Check the hanger rubber and brackets for damage.

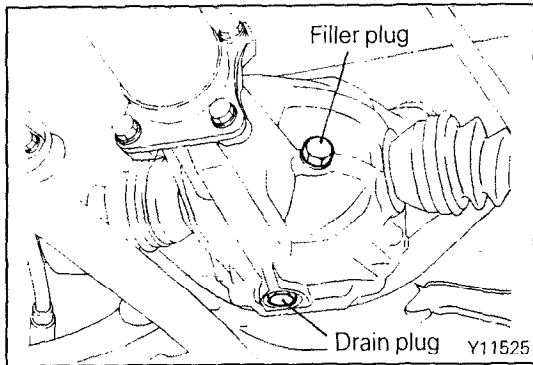
**REAR AXLE**

N00SB0B

INSPECT OIL LEVEL

Remove the filler plug and inspect the oil level at bottom of filler hole. If the oil level is at or slightly below the filler hole, it is in satisfactory condition.

CHANGE OIL

Before changing the rear axle oil, check to make sure that there is no oil leakage from the rear axle housing. Remove the drain plug and drain out all of the oil. Put the oil plug back in place, and then pour new oil in through the filler hole.